



Installation Manual

(Harley Dyna Glide and V-
rod non-inverted fork)

Glenda LED Light Kit
(Dimmable)
Patent Pending



The Clearwater Company
2546 Mercantile Dr. Ste B
Rancho Cordova, CA 95742
P:916.852.7029 F:916.852.9410
www.clearwaterlights.com

Please be sure to read our instructions thoroughly before attempting installation.

Step 1: Parts List and Bike Preparation

- Check Parts list supplied with your kit to be sure all parts are handy. Contact us at (916) 852-7029 if something is missing.
- Park the motorcycle on hard pavement or concrete to insure the bike will be stable during the installation. If you can mount the bike on a stand with tie-down straps, this will help secure the motorcycle
- Follow the manufacturers guidelines for disconnecting the battery. This is important to prevent damage to the electrical system.

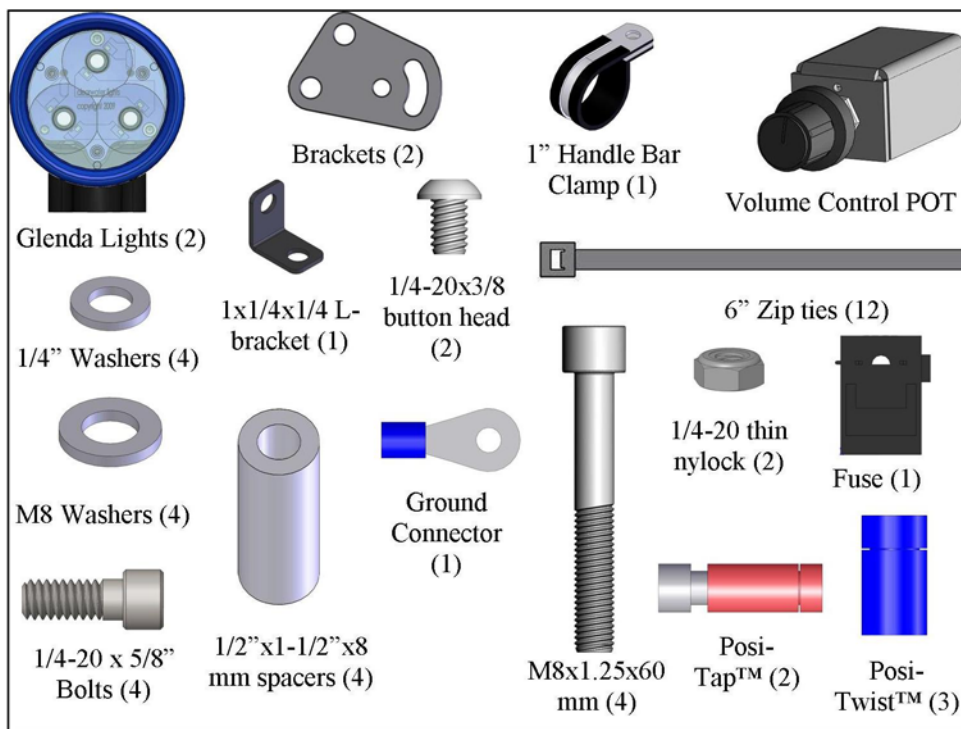

11/22/10

Note: *Clearwater lights include a very high quality means of connecting to the motorcycle's electrical system. "Posi" devices made by Posi-Products are used to securely and safely make electrical connections on the bike. You can view instructions on the proper installation of the Posi-Products at <http://www.posi-lock.com>. They simply screw together and mate the wires. We suggest keeping your lights on all the time, we do not furnish an "on-off" switch. It is important to be sure that the wire you use will turn off when the bike is turned off. Otherwise, you will end up with a dead battery. Nobody likes that.*

Step 2: Mounting the Lights

Mounting Lights (FENDER MOUNT)

- One side at a time, remove both fender bolts. Be sure to keep fender from hanging in a fashion that damages it. Use a wire tie or piece of wire to hold the fender until you are ready to install the new bolts. Inspect the female threads on the brackets for dirt or foreign substance. If possible, use compressed air (wear protective glasses) or small bottle brush to clean the threads
- Pre-assemble the lights, mounting bracket, and spacers with new bolts.
- Gently screw all bolts in hand tight. Inspect the bolt length and spacer alignment before tightening the bolts. Assembly will resemble the exploded diagram below.



Step 3: Mounting the Pot

Mounting Pot Bracket (BAR MOUNT OPTION)

- Mount “volume control” to handlebar by using supplied bracket, bolt and clamp.
- Route wires from lights and pot bracket to area under left side of forks. Connections can be made here and be kept weatherproof.

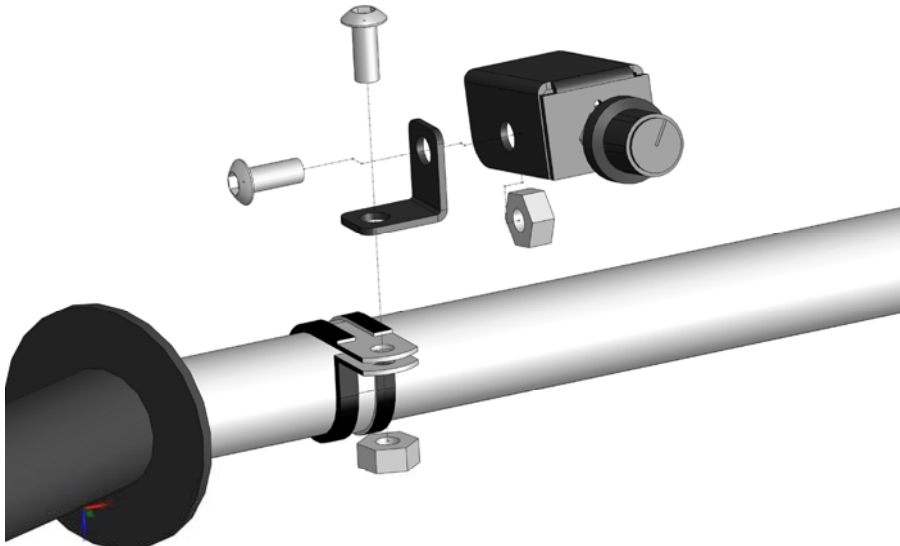

Step 4: Wiring

Wire routing:

- Be sure to route wires so that they cannot become tangled or caught in either a suspension part or steering part. Check movement of both steering and suspension before riding the bike.
- It is sometimes helpful to follow existing wire routing.

Wiring:

- Main power needs to be connected to a SWITCHED HOT. This means one that turns off with the key. An Auxiliary hot can be used as an alternative. Using the supplied Posi-twist connectors, connect the wires according to the accompanying color wire diagram. Attach ground lug to ground on frame tab or other suitable location. Be sure NOT to use a Low beam headlight wire on H4 headlight bikes.
- Find a good solid ground point for the black wire terminal ring.
- Use a posi-twist to connect the green wire from the pot to the two green wires from the lights (3 wires).
- Use a posi-twist to connect red wire from the fuse holder to the red wires from lights and pot (4 wires)
- Connect ground/black wire to black wires from lights and pot. (4 wires)

High Beam Feature

- If you are going to install the high beam feature (and we hope you do) be sure to follow these instructions
- Locate the high beam headlight wire. This will be on ONLY when the high beam is illuminated. This will trigger the pot to control the brightness of the lights. Connect the white wire from the pot to this high beam circuit wire. See diagram for details.

Wiring Diagram for Glenda Lights

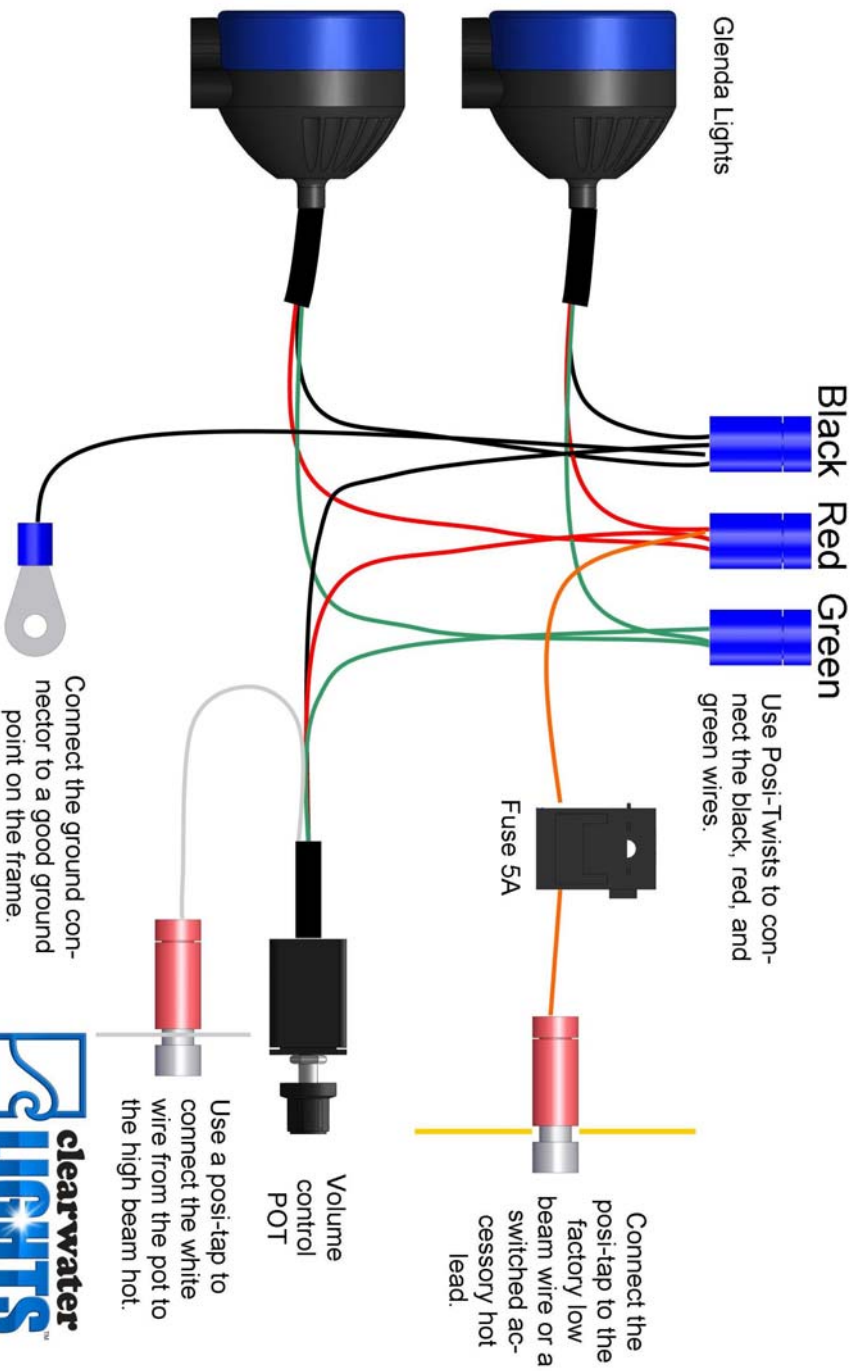

Step 5: Alignment



Ask an assistant to help you with this procedure. Make sure the bike is on level ground and have an assistant sit on the bike. With a right angle board or object, position the board on the floor and slide it up to the light. The goal is to adjust the lights so that the light is level with the ground. Passengers and luggage may alter the alignment of the light, so further adjustments may be needed. You may find that a slight downward angle (5 degrees) is helpful.

Thank you for purchasing your Clearwater lights. We hope this product will help make you a safer rider. Please feel free to send us comments or suggestions at any time. We learn from you. Keep checking our website for more new exciting products to help you see better at night such as our flashlights and our 36W LED Krista Light.

Ride safe!

Sincerely,

Glenn and the guys at Clearwater.



The Clearwater Company
2546 Mercantile Dr. Suite B
Rancho Cordova, CA 95742
Ph:916.852.7029 Fx:916.852.9410
www.clearwaterlights.com

July 20, 2011