

# Wiring Diagram for the Clearwater Voltage Sentry (CVS)

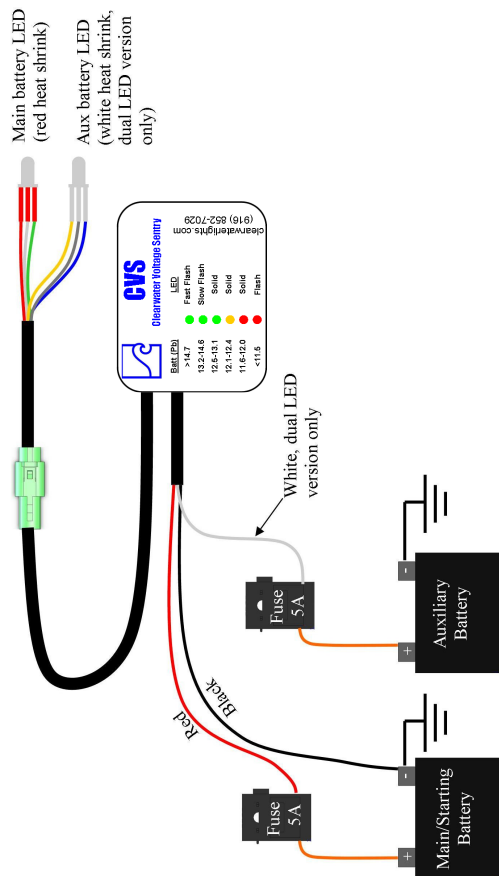

6/15/11



## Installation Manual

### Clearwater Voltage Sentry (CVS)

Digital LED voltage monitor



The Clearwater Company  
 2546 Mercantile Dr. Suite B  
 Rancho Cordova, CA 95742  
 Ph:916.852.7029 Fx:916.852.9410  
 www.clearwaterlights.com

Aug 24, 2011



The Clearwater Company  
 2546 Mercantile Dr. Ste B  
 Rancho Cordova, CA 95742  
 P:916.852.7029 F:916.852.9410  
 www.clearwaterlights.com

**Please be sure to read our instructions thoroughly before attempting installation.**

Thank you for purchasing the Clearwater Voltage Sentry! This amazingly simple yet high tech device will keep you informed about the condition of your battery whenever you use your bike. Our voltage sentry uses a highly accurate and precisely calibrated microprocessor to measure the voltage of your bike's battery within 1/4 of a percent. For contrast, a standard voltage divider based meter reads within 10 to 15 percent. The microprocessor also automatically shuts the unit off after 5 minutes of inactivity and turns it back on as soon as it sees a change in system voltage. To get the most out of your Voltage Sentry, please follow our installation instructions. This unit is accurate from minus 40 degrees to over 200 degrees. Simple to use. No confusing digital readouts, just a three color LED that is programmed to show battery and alternator condition. When the bike is not running, a solid GREEN indicates good condition. When the bike is running, a slow flashing GREEN indicates a good charging condition. It's that simple.

### **Step 1: Mounting**

Mount the CVS unit in a convenient location that does not interfere with the movement of or get pinched by any steering or suspension components. Zip tie all wires in place.

Similarly, mount the LED in an easily viewable location on the dash board or handle bars of your bike. Once again, zip tie all wires in place, and make sure nothing gets pinched or interferes with steering or suspension. Use a 6mm or 1/4" drill for mounting in a panel.

### **Step 2: Wiring**

- Connect the Black wire to the battery's ground (-) terminal.
- Connect the Red wire to the fuse holder using the supplied posi-lock. Fuse holder not necessary if connecting to a fuse/terminal block that already has a fuse.
- Connect the fuse holder to the battery's hot (+) terminal. Alternatively, you can also connect it to a constant hot.
- If you have purchased the dual LED (POLICE and MARINE) version, connect the White wire to the auxiliary battery's hot, using a fuse holder as described above. Attach the green connector from the LED to the green connector on the unit.
- See wiring diagram on page 4.

### **Reading the CVS**

As described earlier, the unit will automatically turn itself on when it senses the bike is active (change in voltage) and will turn itself off after 5 minutes of inactivity. If you wish to check your battery after the unit has shut off, turn the key on for a brief second and turn it back off. The LED will cycle through 5 different patterns as described below based on voltage:

- **Flashing RED:** Indicates Less than 11.5 volts. This is not a good condition for any battery, and could indicate a starved or defective battery. Get a charger on this battery immediately and check to see if it will come back to life.

- **Solid RED:** Indicates between 11.6 and 12.0 volts. Weak battery, start and run the engine for a while or get a charger. If this persists after charging, the battery needs to be replaced. If this occurs while the bike is running, your alternator is bad or severely overloaded.
- **Solid Yellow:** Indicates between 12.1 and 12.4 volts. This indicates the battery needs to be recharged. If this occurs while the bike is running, it means you are drawing a lot more power than the alternator is generating, and potentially a bad alternator.
- **Solid Green:** Between 12.5 and 13.1 volts. Good battery condition with the bike off; poor to weak charging condition with the bike running. This can also indicate your accessories are drawing too much power. **Note:** some bikes do not generate sufficient power at idle. This can be normal. If you get the solid green light while your bike is idling, run the engine faster and it should start flashing green.
- **Slow Flashing Green:** Indicates between 13.2 and 14.6 volts. The battery is charging properly.
- **Fast Flashing Green:** The battery is over 14.6 volts. This indicates an abnormal overcharging situation that could indicate a faulty alternator. Get your electrical system evaluated immediately.

If you have the dual LED version, the color of the heat shrink will match the corresponding color of wire, i.e. red = primary/starting battery, red heat shrink on the LED; white = auxiliary battery, white heat shrink on the LED.

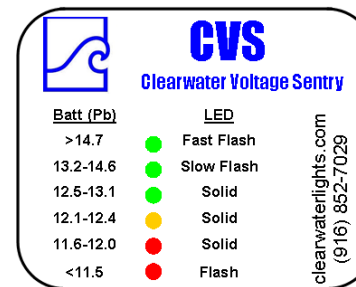

Batt (Pb)	LED
>14.7	● Fast Flash
13.2-14.6	● Slow Flash
12.5-13.1	● Solid
12.1-12.4	● Solid
11.6-12.0	● Solid
<11.5	● Flash

cleanwaterlights.com  
(916) 852-7029

Thank you for purchasing your Clearwater Voltage Sentry. Please feel free to send us comments or suggestions at any time. We learn from you. Keep checking our website for more exciting products such as our 36W LED Krista light to help you see better at night.

Ride safe!

Sincerely,

Glenn and the Staff at Clearwater.